

DH2 ISLA 985

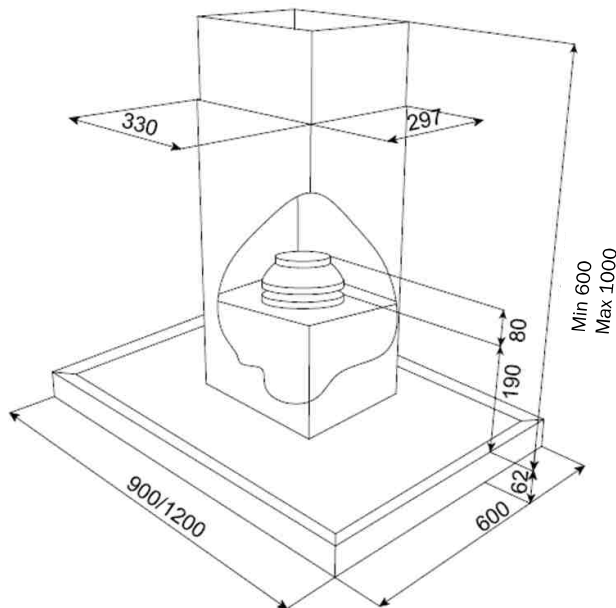

CHARACTERISTICS

- Backlit electronic control with white display
- Upper Body of Reinforced Black Glass
- Easy to clean inside panel
- Conventional extraction
- 3 speeds + Intensive
- Stop delay timer
- Filter saturation indicator
- LED 4x3W lamps
- Decorative Stainless Steel filters
- Double turbine motor
- Reduction 150/120mm included
- European plug included
- Optional recirculation mode (SET 1/T)
- Annual Energy Consumption (AEC_{hood}) kWh/a 47,8
- Energy Efficiency class A
- Fluid Dynamic Efficiency (FDE_{hood}) 32,3
- Fluid Dynamic Efficiency class A
- Light Efficiency (Lehood) lux/Watt 58,3
- Lighting Efficiency class A
- Grease Filtering Efficiency (GFE_{hood}) % 83,4
- Grease Filtering Efficiency class C
- Air flow (Qmin) m³/h 311
- Air flow (Qmax) m³/h 605
- Air flow (Qboost) m³/h 796
- Noise (LwA) Min Speed dB 52
- Noise (LwA) Max Speed dB 66
- Noise (LwA) Boost Speed dB 71
- Off mode Power (Po) W 0
- Standby Power (Ps) W 0,56
- Energy Efficiency Index (EEI_{hood}) 50,1
- Time increase actor (f) 0,8
- Air flow at best efficiency point (Qbep) m³/h 341
- Air pressure at best efficiency point (Pbep) Pa 456
- Electric power input at best efficiency point (Wbep) W 133,7
- Nominal power of the lighting system (WL) W 12
- Average illumination of the lighting system on the cooking surface (Emiddle) Lux 700

MODEL	TKI CODE	EAN CODE
DH2 ISLA 985	40484640	8421152145715

